

All Kinds of Thermowells

طراحی، محاسبه و ساخت انواع ترموولها بر اساس استانداردهای ASME B16.5, ASME PTC19.3 جهت مصارف صنایع نفت، گاز، پالایش و پتروشیمی تولید با متریالهای Hastelloy C, Monel, SS316L, SS304L, Alloy600 و متریالهای مورد نیاز دیگر پذیرفته شده در وندور لیست شرکتهای نفت، گاز، پالایش و پتروشیمی و شرکتهای تابعه

APPLICATION:

STRENGTH CALCULATION محاسبه

Petrochemical, Oil, Gas, On/Off Shore, Plant engineering.

Chemical engineering, Process engineering, Apparatus engineering.

Wide range of applications in Machine, Tank, Pipeline, Apparatus construction and heating technology for low, medium and high process loads.



Material:	Stainless steel 304L,316L(NACE) , Inconel , hastelloy , PTFE coating
Insertion Length(U):	To customer specification (max.:3000mm)
Bore size:	6mm, 7mm, 8mm, 10mm, ...
Connection to the thermometer:	1/2NPT , 1NPT , 3/4NPT , G1/2 , G3/4
Process connection:	Flange (RF, RTJ) , Weld , Thread
Class:	150 , 300 , 600 , 900 , 1500 , 3000 , 5000 , 10000

THERMOWELL

Flanged Thermowell

DTW1 THERMOWELL			
#1	CONFIGURATION		
A	Step shank (Standard)	B	Built-up Thermowell
S	Straight shank	X	Other specify
T	Tapered shank		
#2	BORE SIZE		
	6mm 8mm Other specify		
#3	U LENGTH (mm)		
#4	WELL AND FLANGE MATERIAL		
C	Carbon steel		
S	304 L SS		
L	316 L		
M	Inconel 600		
H	Hastelloy C-276		
X	Other specify		
#5	SIZE OF FLANGE		
3	1"	5	2"
4	1 1/2"	X	Other specify
#6	FLANGE RATING		
A"	150	E	1500
B"	300	F	3000
C"	600	X	Other specify
D"	900		
#7	FLANGE RATING		
1	Rasised face (RF)		
2	Ring Joint Type (RTJ)		
x	Other specify		

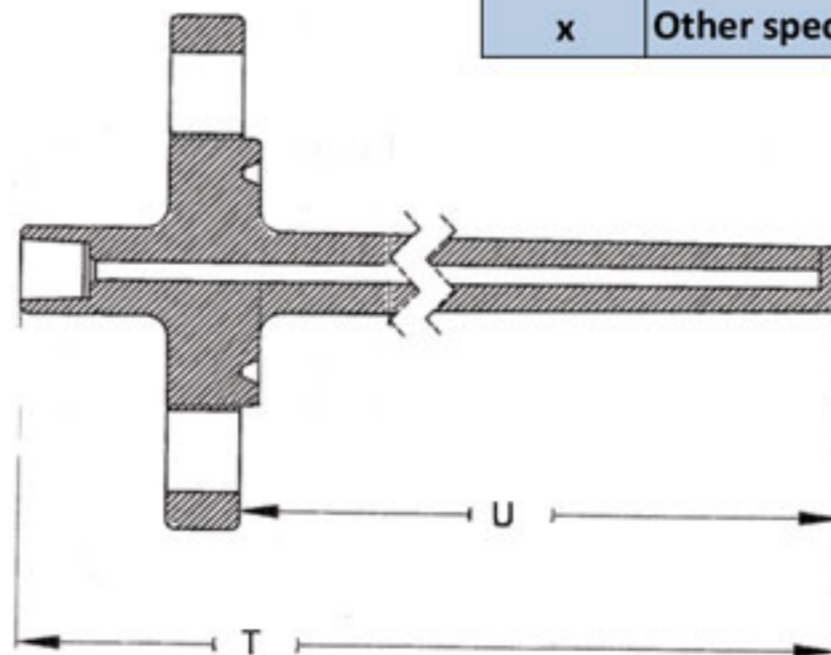
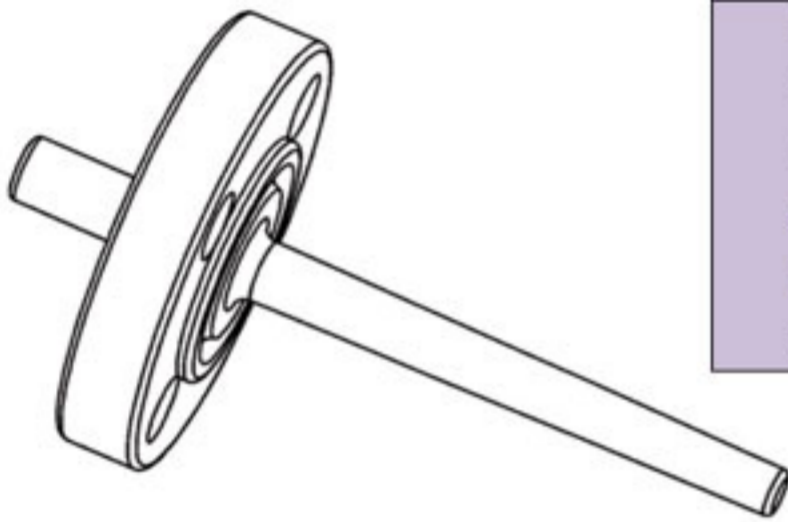

DTW1	A	2	3	0	0	0	L	3	B	X
------	---	---	---	---	---	---	---	---	---	---

THERMOWELL



DTW2	THERMOWELL	
#1	CONFIGURATION	
A	Step shank	
S	straight shank	
T	Tapered shank	
X	Other specify	
#2	BORE SIZE	
2	6mm	
3	8mm	
X	Other specify	
#3	U LENGTH (mm)	
#4	WELL AND MATERIAL	
E	F22	
F	F11	
C	Carbon steel	
S	304 L Stainless steel	
J	310 Stainless steel	
K	316 Stainless steel (Standard)	
L	316 L Stainless steel	
M	Inconel 600	
N	Monel 400	
H	Hastelloy C-276	
S	Titanium	
X	Other specify (i.e. : Teflon , PVC , Nickel , etc ,.....)	
#5	THREADED OR SOCKET WELD WELLS	
T	Threaded well	
S	Socket weld well	
W	weld-in (Tapered shank standard)	
X	Other specify	
#6	THREADED WELLS / EXTERNAL THREAD	SOCKET WELL WELDOLET SIZE
1	1/2" NPT	N/A
2	3/4" NPT	3/4" 1.050" Ø
3	1" NPT	1" 1.315" Ø
4	1 1/2" NPT	1 1/2" 1.900"
X	Other specify	

Mechanical product

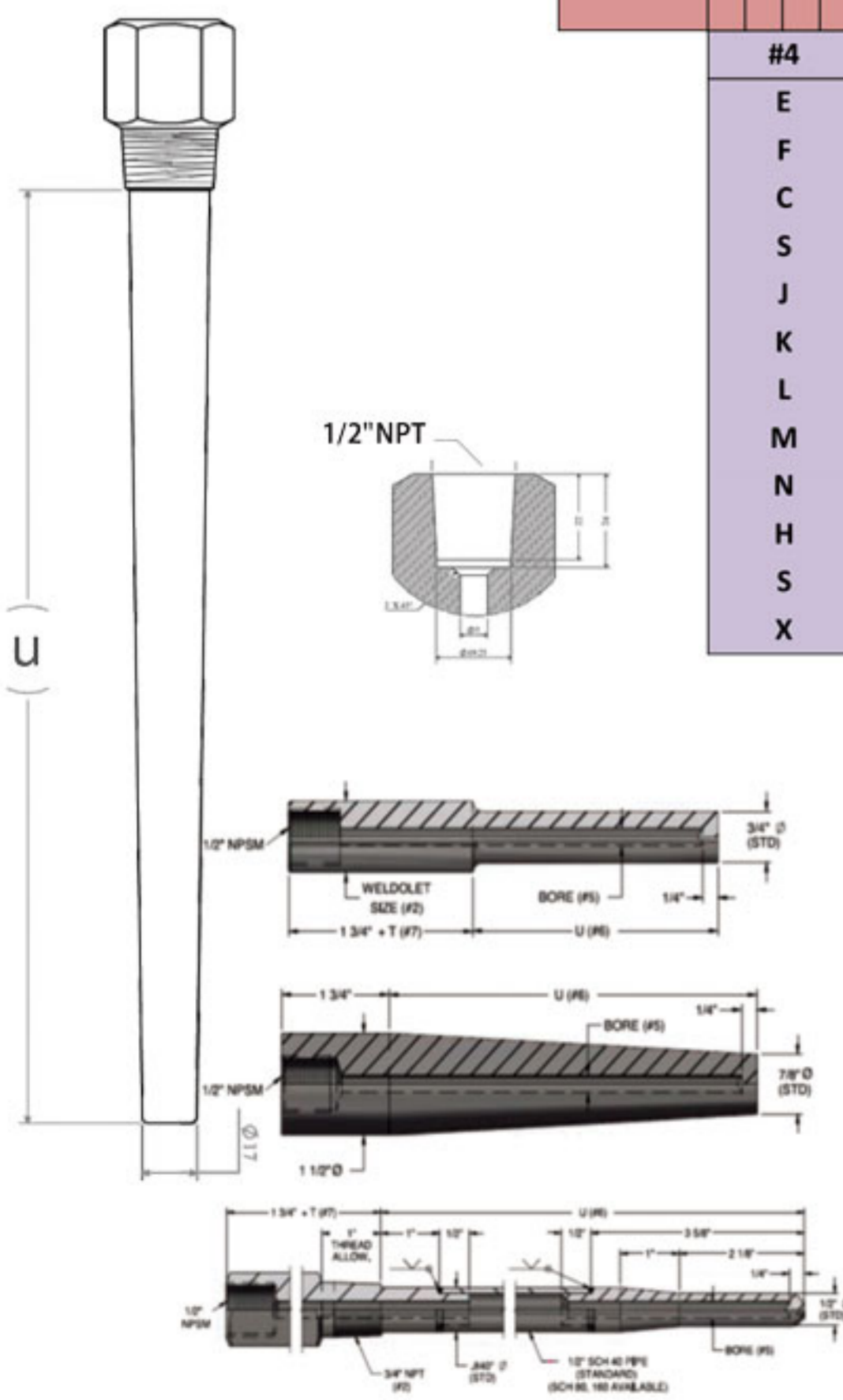

DTW2 A 2 3 0 0 0 L T 1

